



AUF G10

SPECIFICATION

HOUSING :GLASS OF REINFORCED POLYESTER RIGID EVEN AT HIGHER TEMPERATURE
:STAINLESS STEEL CLIPS
:EXPANDED AND INJECTED POLYURETHANE SEAL FOR EFFECTIVE SEALING BETWEEN BODY AND DIFFUSER

REFLECTOR :STEEL SHEET MATERIAL, POWDER COATED WHITE
UV-PROTECTION

(OPTIONAL) :PARABOLIC HIGH PURITY ANODIZED ALUMINIUM 99.85% MIRROR FINISH, TOTAL REFLECTION 87% (DIN 5036-3)FROM GERMANY
:PARABOLIC HIGH PURITY ANODIZED ALUMINIUM 99.99% MIRROR FINISH, TOTAL REFLECTION 95% (DIN 5036-3)FROM GERMANY

DIFFUSER :POLYCARBONATE

WIRES :THW, TIS.11-1988 STANDARD

LAMP HOLDER :ROTOR LOCKET TYPE HIGH-HEAT RESISTANCE, TIS344-1987 STANDARD

PROTECTION CLASS :PROTECTION CLASS EQUIVALENT TO IP65 CLASS I

COLOR :GREY

INSTALLATION :SURFACE OR SUSPEND MOUNT

APPLICATION :FACTORY, WAREHOUSE, CLEANROOM, ETC.
:CAN BE USE IN COLD STORAGE ROOM -30 C AMBIENT TEMPERATURE

COMPLETE SET* :INCLUDING BALLAST, LAMP, STARTER NORMAL FOR T8 LAMP

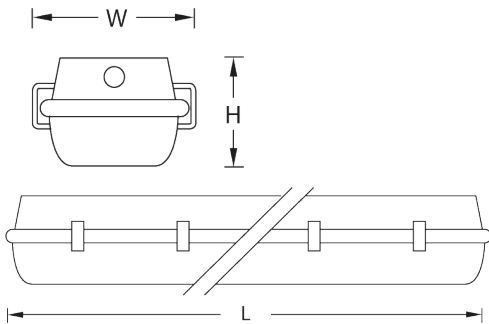

MODEL	LAMP	DIMENSION(mm.)			WEIGHT (kg.)
		L	W	H	
AUF G10-140	1 x 36W. T8	1310	110	108	4.20
AUF G10-240	2 x 36W. T8	1310	170	108	6.30
AUF G10-158	1 x 58W. T8	1580	110	108	6.40
AUF G10-258	2 x 58W. T8	1580	170	108	8.20

INSTALLATION : SURFACE MOUNT OR SUSPEND MOUNT